



### Technical Specification

#### Camera

Image Sensor	1/2.8" CMOS
Max. Resolution	1920 (H) × 1080 (V)
Pixel	2MP
Scanning System	Progressive
Electronic Shutter Speed	PAL: 1/25 s–1/100,000 s NTSC: 1/30 s–1/100,000 s
S/N Ratio	> 65 dB
Min. Illumination	0.001 Lux/F1.6, 30IRE, 0 Lux LED on
Illumination Distance	40 m (131.2 ft)
Illuminator On/Off Control	Auto; manual
Illuminator Number	2
Pan/Tilt/Rotation Range	Pan: 0°–360° Tilt: 0°–78° Rotation: 0°–360°

#### Lens

Lens Type	Fixed lens				
Mount Type	M12				
Focal Length	2.8 mm				
Max. Aperture	F1.6				
Field of View	2.8 mm: H: 107°; V: 56°; D: 127°				
Iris Type	Fixed iris				
Close Focus Distance	2.8 mm: 0.7 m (2.3 ft)				
DORI Distance	Lens	Detect	Observe	Recognize	Identify
	2.8 mm	43.9 m (144 ft)	17.5 m (57.4 ft)	8.8 m (28.9 ft)	4.4 m (14.4 ft)

#### Video

Frame Rate	CVI: PAL: 1080p@25 fps; NTSC: 1080p@30 fps; AHD: PAL: 1080p@25 fps; NTSC: 1080p@30 fps; TVI: PAL: 1080p@25 fps; NTSC: 1080p@30 fps; CVBS: PAL: 960 × 576H; NTSC: 960 × 480H
Resolution	1080p (1920 × 1080); 960H (960 × 576/960 × 480)
BLC	BLC/WDR/HLC
WDR	130 dB
White Balance	Auto; Area WB

Gain Control	Auto; manual
Noise Reduction	3D NR
Smart Light	Yes
Mirror	Off/On
Privacy Masking	Off/On (8 area, rectangle)

#### Certifications

Certifications	CE (EN55032, EN55024, EN50130-4) FCC (CFR 47 FCC Part 15 subpartB, ANSI C63.4-2014) UL (UL60950-1+CAN/CSA C22.2 No.60950-1)
----------------	---

#### Port

Video Output	Video output choices of CVI/TVI/AHD/CVBS by one BNC port
Audio Input	One channel built-in mic (-A)

#### Power

Power Supply	12 V ±30% DC
Power Consumption	Max 5.1 W (12 V DC, LED on)

#### Environment

Operating Temperature	–40 °C to +60 °C (–40 °F to 140 °F); < 95% (non-condensation)
Storage Temperature	–40 °C to +60 °C (–40 °F to 140 °F); < 95% (non-condensation)
Protection Grade	IP67

#### Structure

Casing	Metal throughout the whole casing
Camera Dimensions	φ106.0 mm × 93.6 mm (φ4.17" × 3.69")
Net Weight	0.46 kg (1.01 lb)
Gross Weight	0.58kg (1.28 lb)

**Accessories**

**Optional:**



PFA139  
Junction box



PFA130-E  
Water-proof Junction Box



PFB205W  
Wall Mount Bracket



PFA106+PFB220C  
Adapter Plate of Mini Dome  
& Eyeball Camera + Ceiling  
Mount Bracket of Mini Dome  
& Eyeball Camera



PFA152-E+PFB205W  
Pole Mount Bracket + Wall  
Mount Bracket



PFM820  
UTC Controller

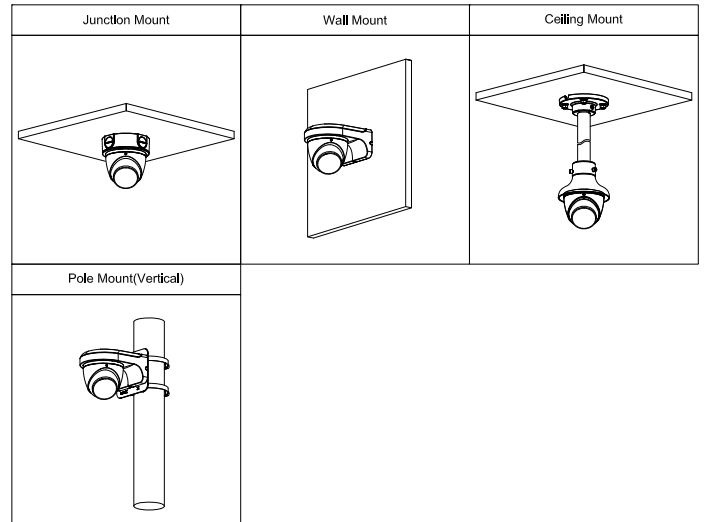

**Dimensions (mm [inch])**

