

Technical Specification

Camera

Image Sensor	5MP CMOS
Max. Resolution	2880 (H) × 1620 (V)
Pixel	5MP
Scanning System	Progressive
Electronic Shutter Speed	PAL:1/3 s–1/100,000 s NTSC:1/4 s–1/100,000 s
S/N Ratio	> 65 dB
Min. Illumination	0.001 Lux/F1.0, 0 Lux warm light on
Illumination Distance	40 m (131.2 ft)
Illuminator On/Off Control	Auto; manual
Illuminator Number	2
Pan/Tilt/Rotation Range	Pan: 0°–360° Tilt: 0°–78° Rotation: 0°–360°

Lens

Lens Type	Fixed lens				
Mount Type	M12				
Focal Length	2.8 mm				
Max. Aperture	F1.0				
Field of View	2.8 mm: H: 112°; V: 57°; D: 132°				
Iris Type	Fixed iris				
Close Focus Distance	2.8 mm: 1.6 m (5.25 ft)				
DORI Distance	Lens	Detect	Observe	Recognize	Identify
	2.8 mm	67.4 m (212.3 ft)	27.0 m (88.6 ft)	13.5 m (44.3 ft)	6.7 m (22.0 ft)

Video

Frame Rate	CVI: PAL: 5M@25 fps; 4M@25 fps; 1080p@25 fps NTSC: 5M@25 fps; 4M@30 fps; 1080p@30 fps AHD: PAL: 4M@25 fps; NTSC: 4M@30 fps TVI: PAL: 4M@25 fps; NTSC: 4M@30 fps CVBS: PAL: 960H; NTSC: 960H
Resolution	5M (2880 × 1620); 4M (2560 × 1440); 1080p (1920 × 1080); 960H (960 × 576/960 × 480)
BLC	BLC/HLC/WDR/HLC-Pro
WDR	120 dB
White Balance	Auto; Area WB

Gain Control	Auto; manual
Noise Reduction	3D NR
Smart Light	Yes
Mirror	Off/On
Privacy Masking	Off/On (8 areas, rectangle)

Certifications

Certifications	CE (EN55032, EN55024, EN50130-4, EN60950-1) FCC (CFR 47 FCC Part 15 subpartB, ANSI C63.4-2014) UL (UL60950-1+CAN/CSA C22.2 No.60950-1)
----------------	--

Port

Video Output	Video output choices of CVI/TVI/AHD/CVBS by one BNC port
Audio Input	One channel built-in mic (-A)

Power

Power Supply	12 V ±30% DC
Power Consumption	Max 6.4 W (12 V DC, warm light on)

Environment

Operating Temperature	–40 °C to +60 °C (–40 °F to +140 °F); < 95% (non-condensation)
Storage Temperature	–40 °C to +60 °C (–40 °F to +140 °F); < 95% (non-condensation)
Protection Grade	IP67

Structure

Casing	Metal throughout the whole casing
Camera Dimensions	φ106.0 mm × 93.6 mm (φ4.17" × 3.69")
Net Weight	0.48 Kg (1.06 lb)
Gross Weight	0.67 Kg (1.48 lb)

Accessories

Optional:



PFA139
Junction box



PFA130-E
Water-proof Junction Box



PFB205W
Wall Mount Bracket



PFA106+PFB220C
Adapter Plate of Mini Dome &
Eyeball Camera + Ceiling Mount
Bracket of Mini Dome & Eyeball
Camera



PFA152-E+PFB205W
Pole Mount Bracket +
Wall Mount Bracket

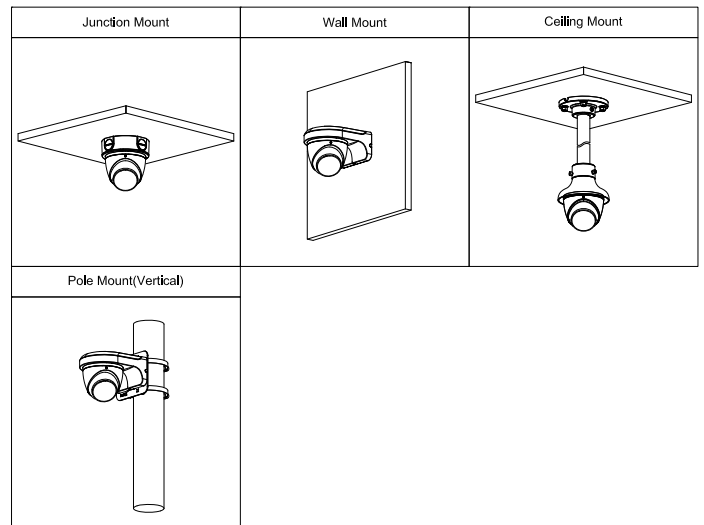

Dimensions (mm[inch])

