

# PFA137

## WATER-PROOF JUNCTION BOX



### FEATURES:

- Aesthetic design
- Material: Aluminum
- Water-proof junction box

### Specifications:

<b>Model</b>	<b>PFA137</b>
<b>General</b>	
Material	Aluminum
Dimension	φ122.0mmx34.2mm (φ4.80" x 1.35")
Inch Thread	M20(G1/2")
Load Bearing	1.0Kg (2.2lb)
Weight	0.24Kg (0.53lb)
Color	White
Operating Temperature	-40°C ~+60°C (-40°F~+140°F)
Humidity	0~90% RH
Applicable Model	TDODCS230V, TDODHS2.430MS, TDOEHS2.60M, TDODHS430M, TDODHS8302, TDODIA330M, TDODIS450M

## Dimensions (mm):

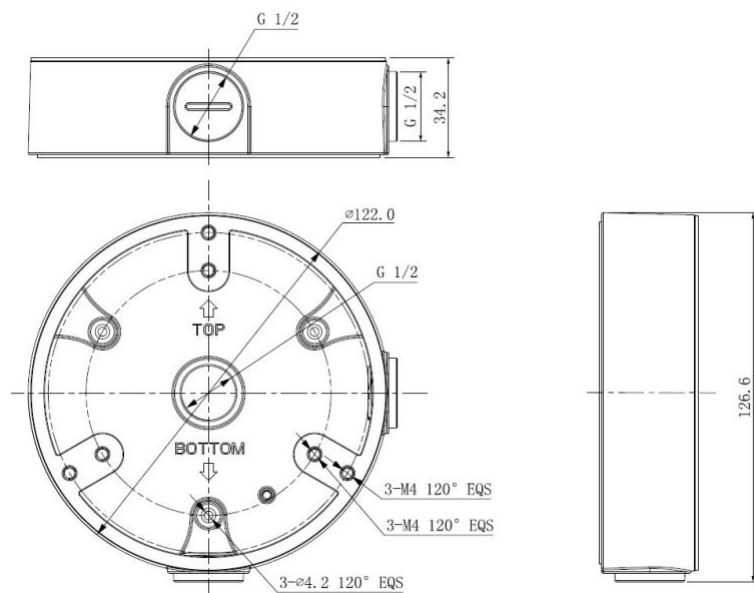

## Application:

