

PFA101

Mount Adapter



- Aesthetic design
- Aluminum material
- Mount adapter

Technical Specifications

| | |
|-----------------------|--------------------------------|
| Model | PFA101 |
| General | |
| Material | Aluminum |
| Dimension | Φ159mm x 35mm (Φ6.26" x 1.38") |
| Pipe Thread | G1 1/2" |
| Load Bearing | 3.0kg (6.61lb) |
| Weight | 0.24 kg (0.53lb) |
| Color | White |
| Operating Temperature | -40° ~+ 60° (-40° ~+140°) |
| Humidity | <90% RH |

Order Information

| Type | Part Number | Description |
|--------------|-------------|---------------|
| Camera Mount | PFA101 | Mount adapter |

Dimensions (mm/inch)

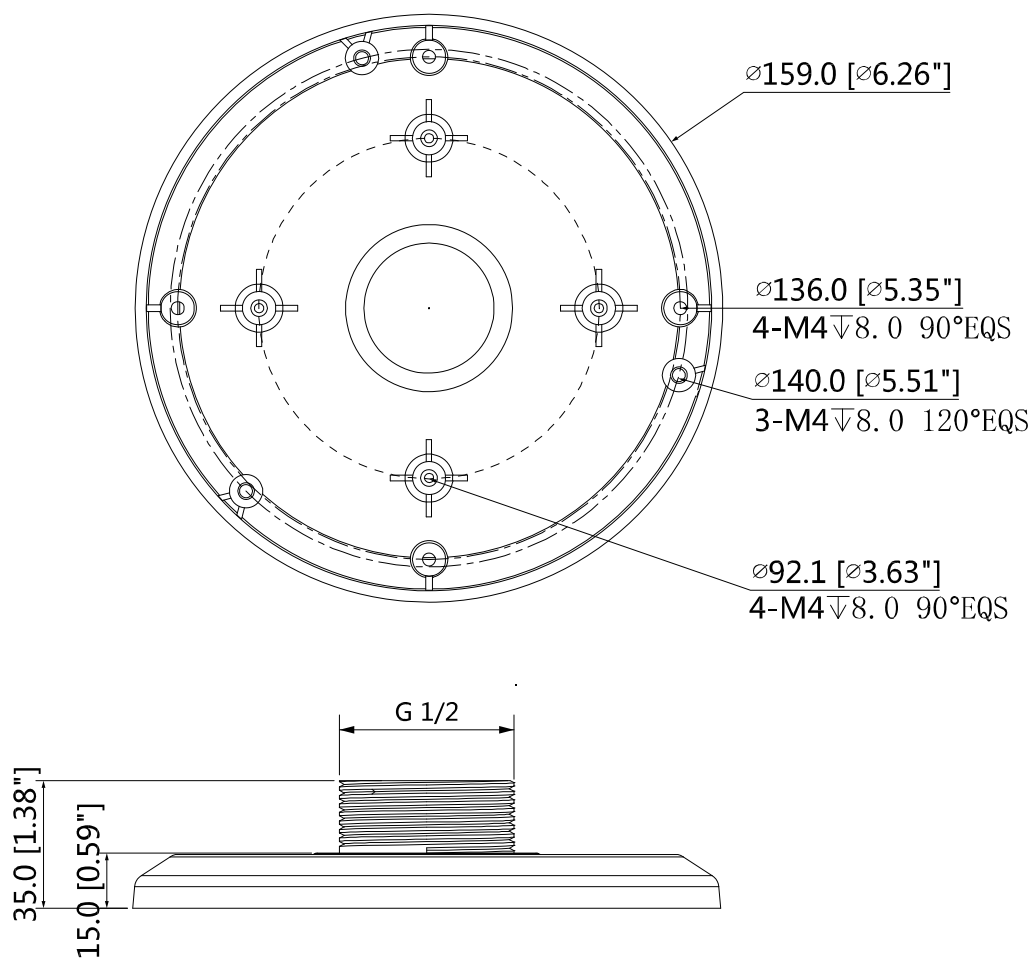

Application

